



**Инструкция по монтажу
тягово-цепного устройства
шарового типа 3040 А
для автомобилей
Toyota Land Cruiser Prado
Lexus GX 470**

	2002/10-...
	1500
	75
	17.0



462800,

т. (35363) 7-05-06

ф. (35363) 7-13-20

(495) 785-66-07

www.bosal-autoflex.ru

« - »	(8182) 22-48-15
"	8(8442) 98-74-98
"	8(343) 379-39-89, 373-42-73
"	8(343) 26-88-308
"	8(3952) 710-194
"	8(495) 777-54-59
"	8(495) 745-79-11
"	8(495) 788-95-97
"	8(495) 720-51-03
"	8(3532) 57-99-85
"	8-905-899-5012
"	8(383) 291-59-60
"	8(831) 279-53-24
"	8(3422) 98-27-20
"	8(342) 220-87-87
"	8-927-002-90-06
"	8(3462) 24-00-44
"	8(3842) 21-14-76
"	8-902-940-4151
"	8(3452) 32-22-12, 41-52-62
"	8-961-213-0278
"	8-917-347-1700
"	8(351) 269-44-75, 900-72-73
"	8(3512) 773-76-91

..... :

..... VIN

.....

.....

41.55-2005.

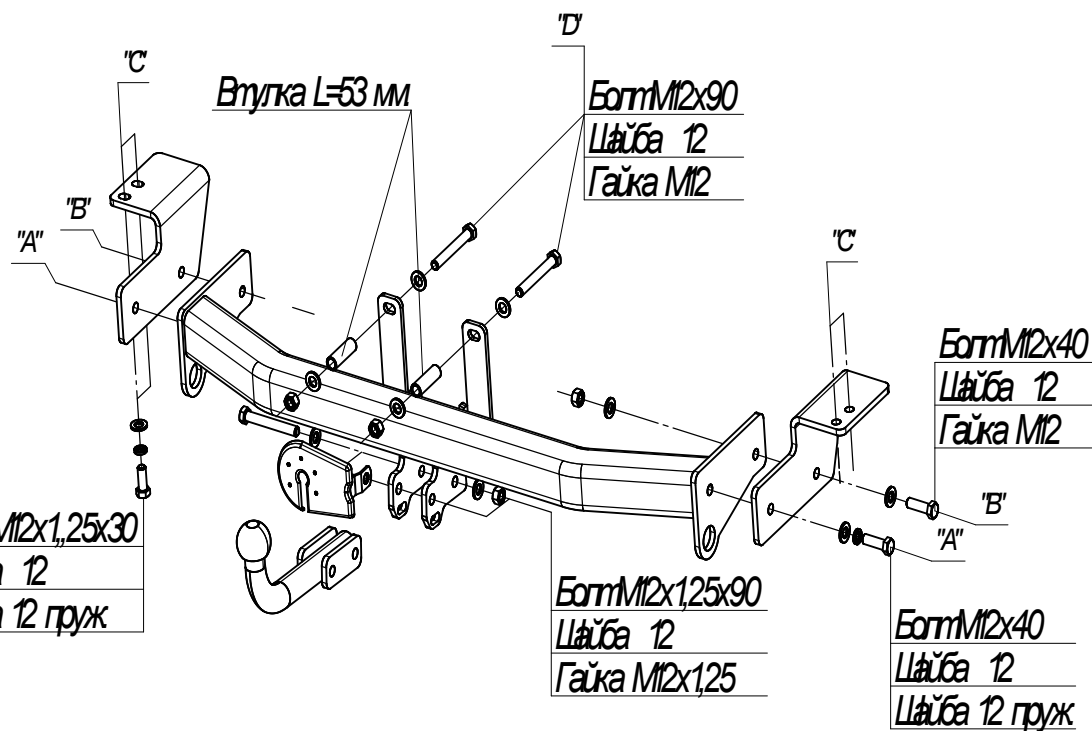

6 ()
 Ø18 ()
 12 30. ()
 12 90, ()
 6. 6 12 ()

	1
	1
	1
	1
	1

	3
12 1,25 /	4
12 /	2
12	18
12	6
12 1,25 30	4
12 40	4
12 1,25 90	2
12 90	2
L = 53	2
6 12 ()	2
6 . ()	2
	2
0800	1
	1
	1
	1
190	1
	1

