

---

Fitting instructions

---

Make: Lexus

---

RX300/RX350/RX400h; 2003->

---

Type: 3653

---

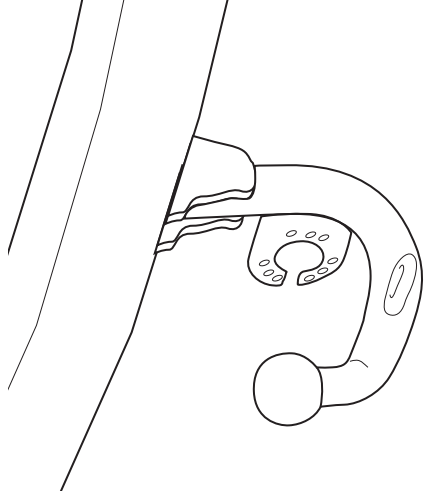

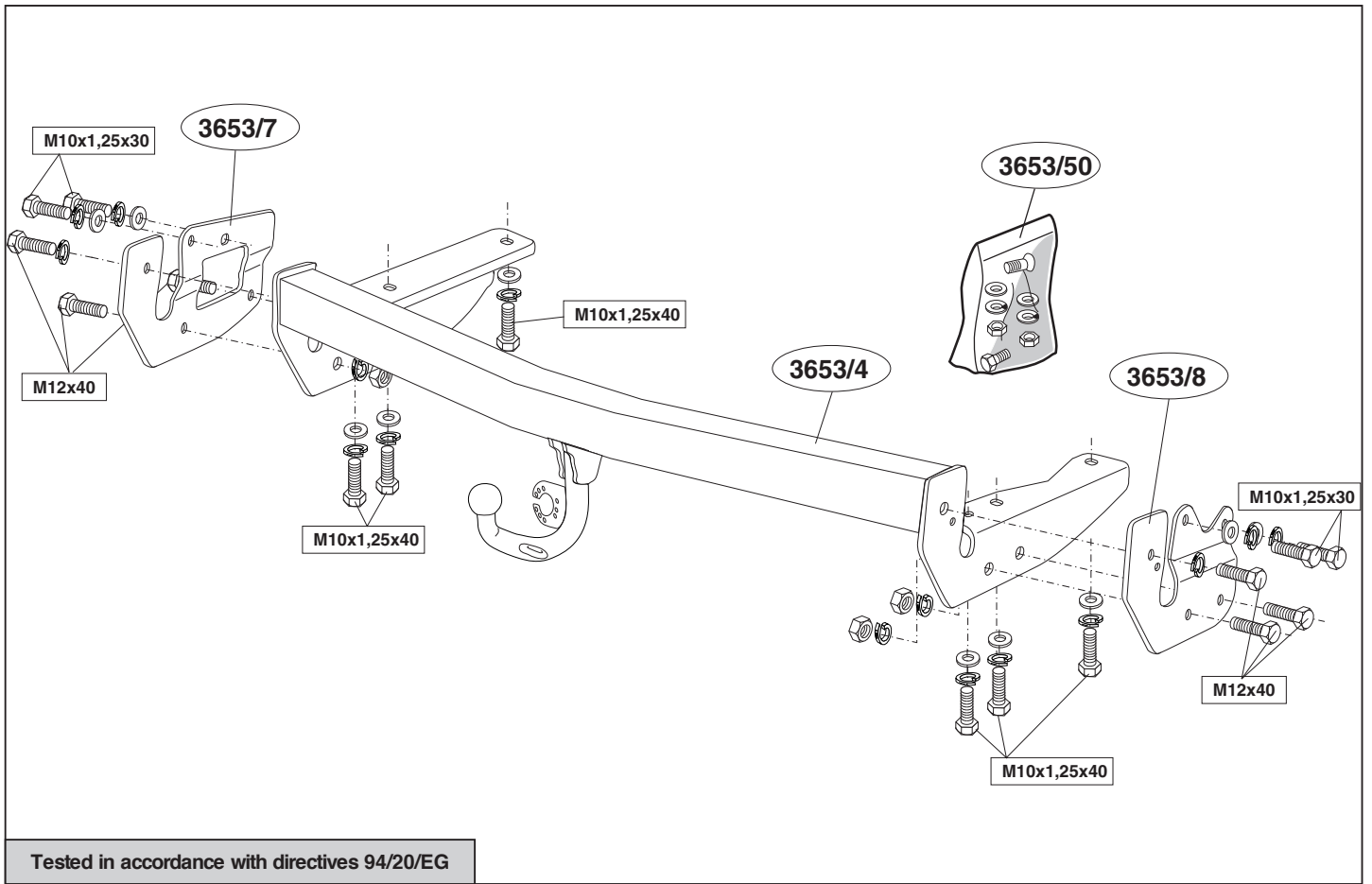

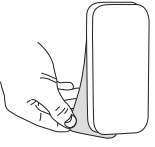



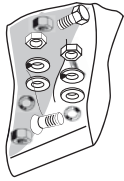
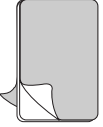





TAPE: 8600489

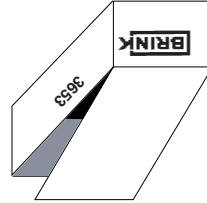
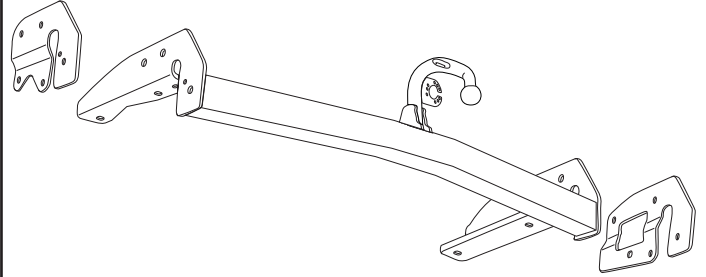
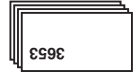

- (4x) M12 
- (6x) M12 
- (10x) M10 
- (10x) M10 
- (6x) M12x40 
- (6x) M10x1.25x40 
- (4x) M10x1.25x30 

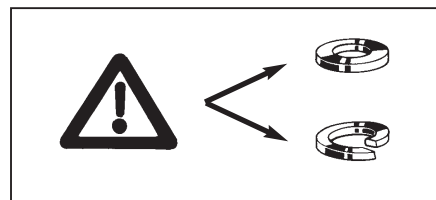
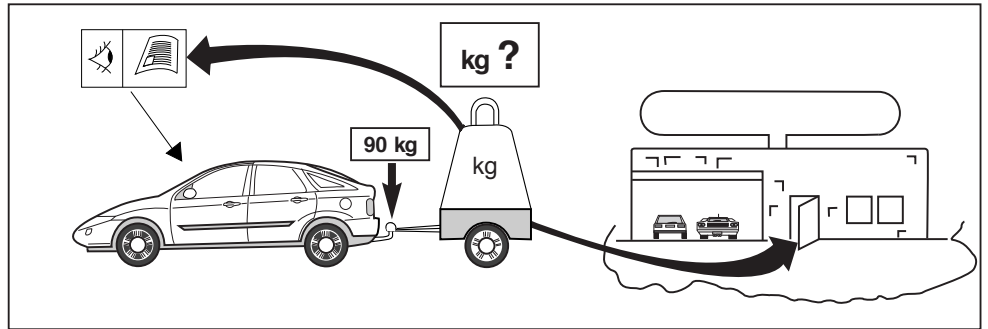
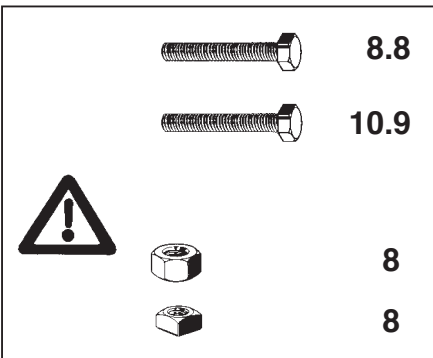
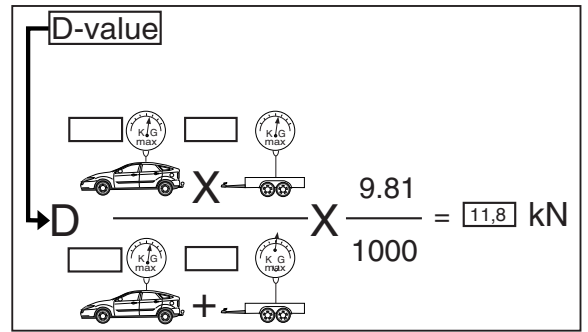
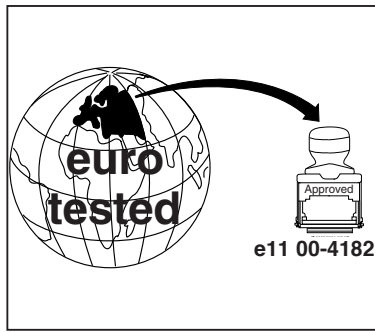
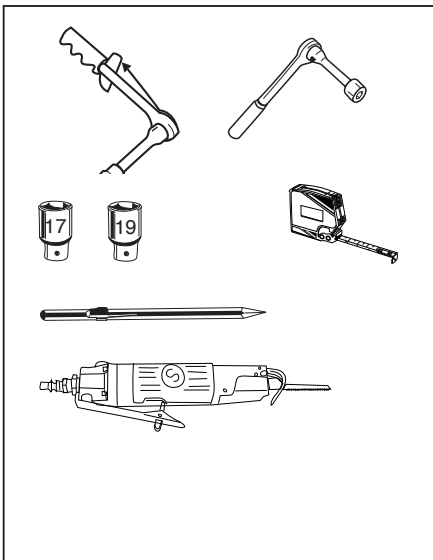



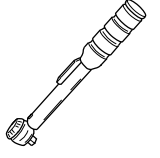

  
1000km

  
0km



---

  
M12  
79 Nm

  
M10x1,25  
53 Nm

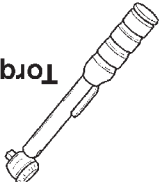

**Torque settings for nuts and bolts (8.8)**

**HINWEISE:**

\* Die für das Fahrzeug zugelassene Anhängelast ist den Fahrzeug Unterlagen zu entnehmen. Bei Änderungen des Fahrzeuggewichtes muß die höchstzulässige Anhängelast gegebenenfalls aus dem D-Wert nachgerechnet werden.

\* Auskunft hierüber kann ihr Fachhändler oder der TÜV geben.

\* Elektrische Anlage gemäß StVZO anbringen.

  
79 Nm  
(6x) M12

  
53 Nm  
(10x) M10x1,25

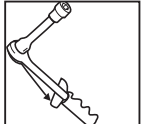

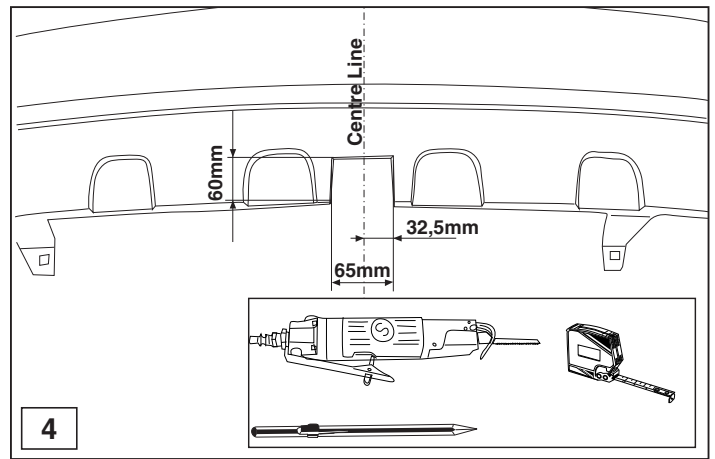
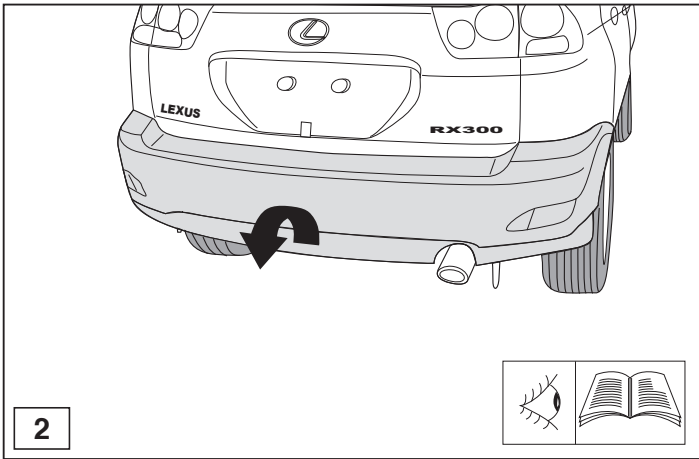
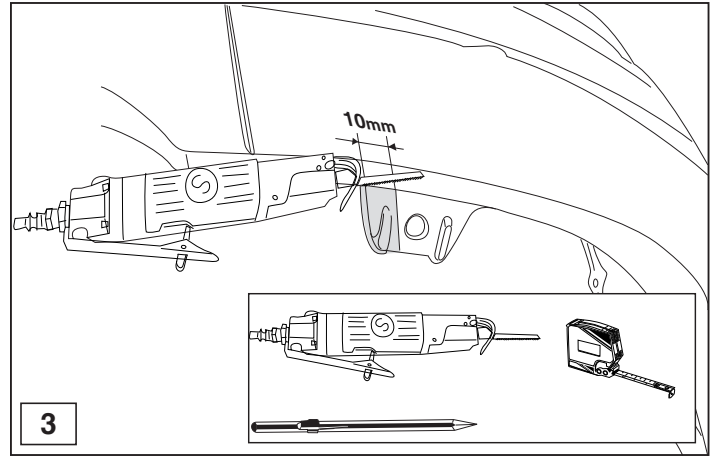
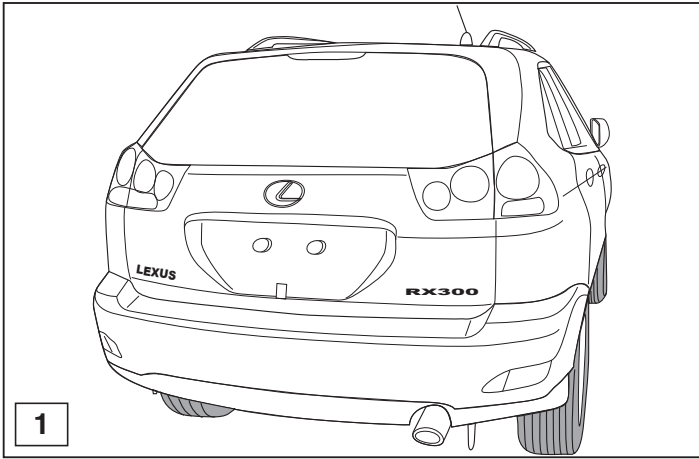
© 365370/16-06-2010/5



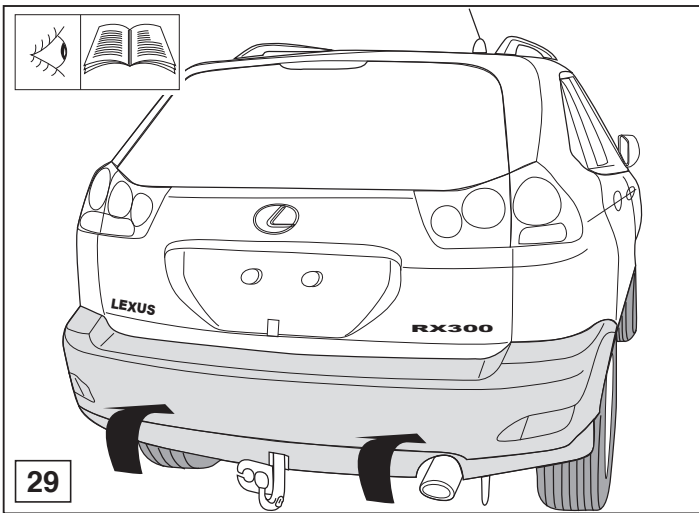

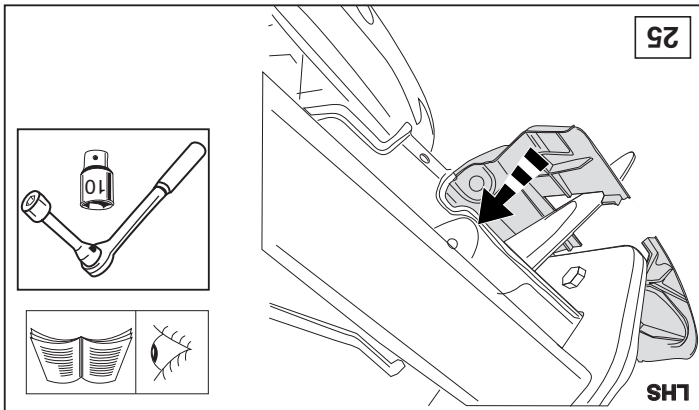
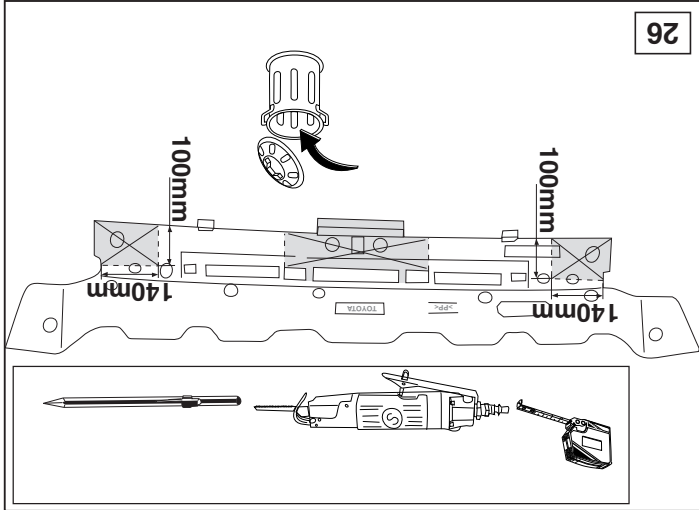
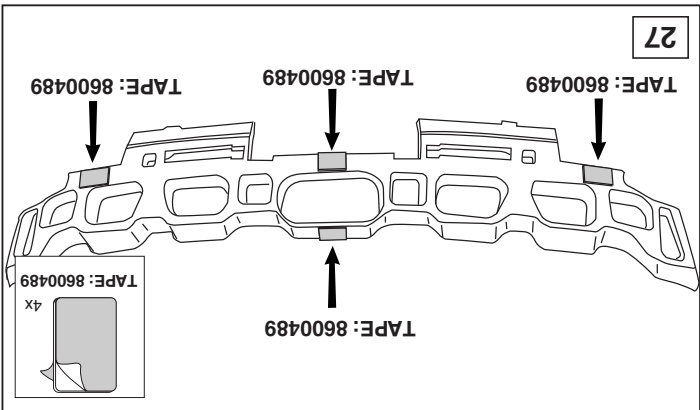
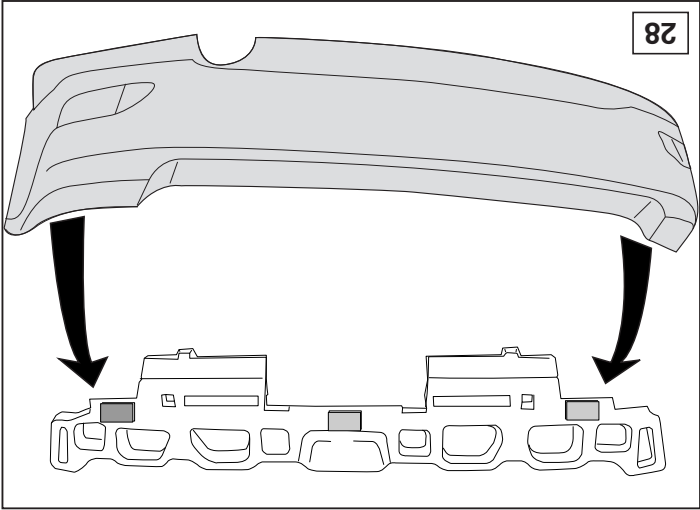
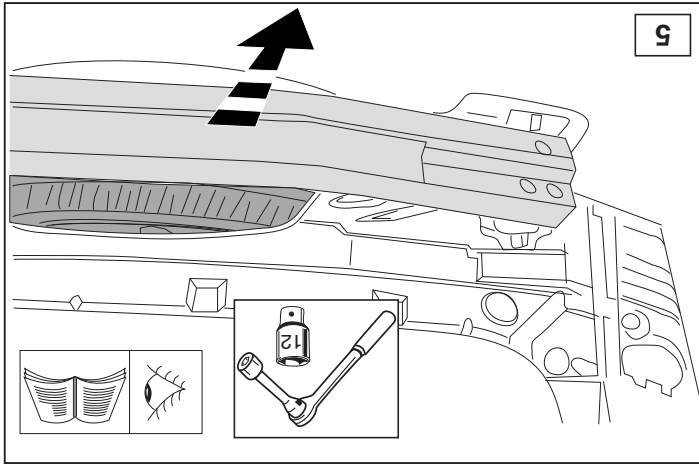
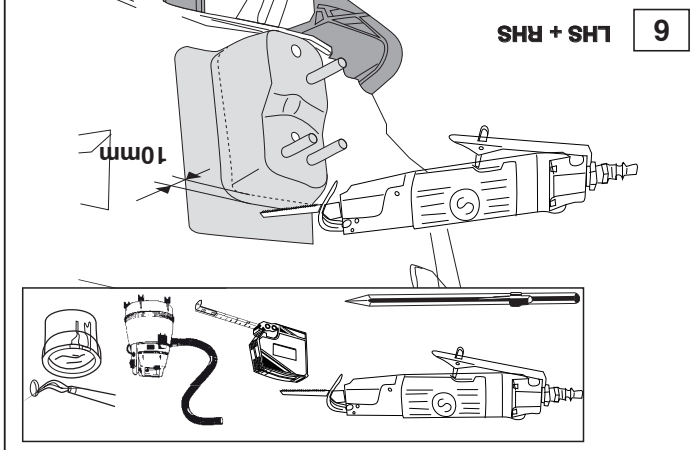
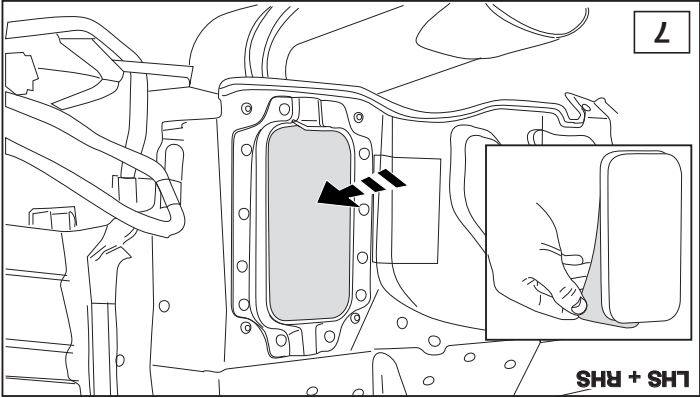
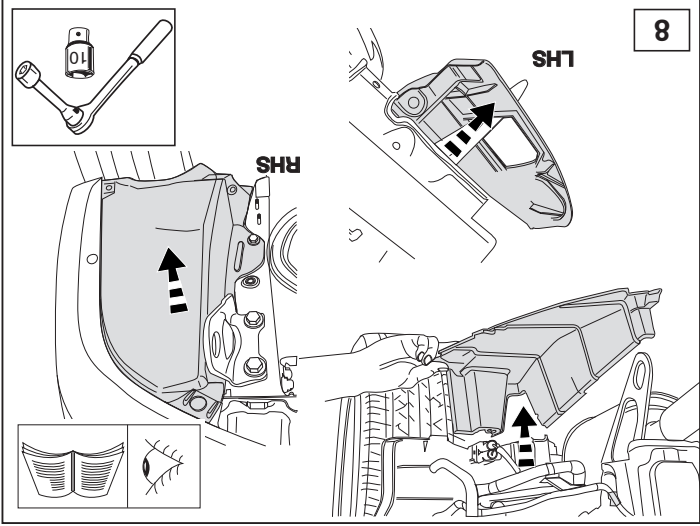
LHS + RHS

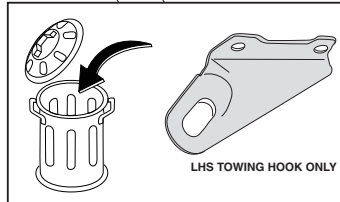
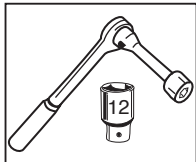
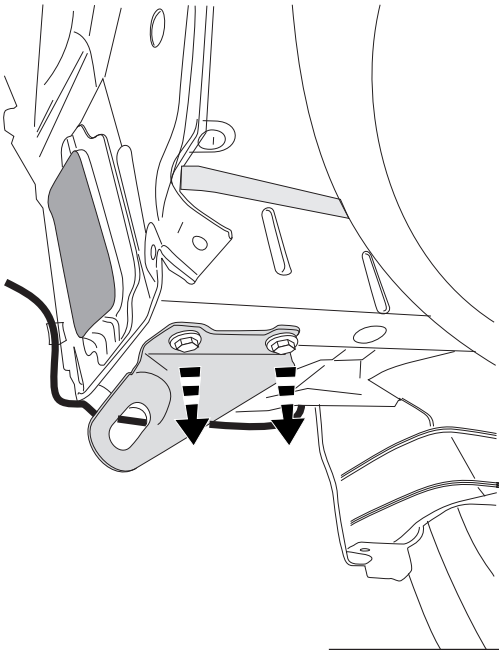

9

LHS

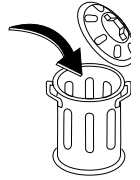
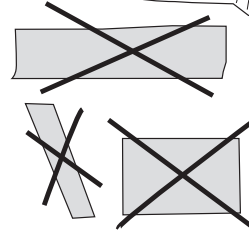
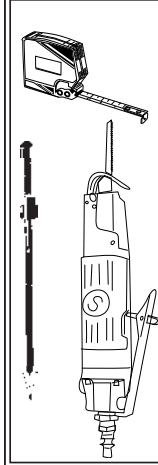
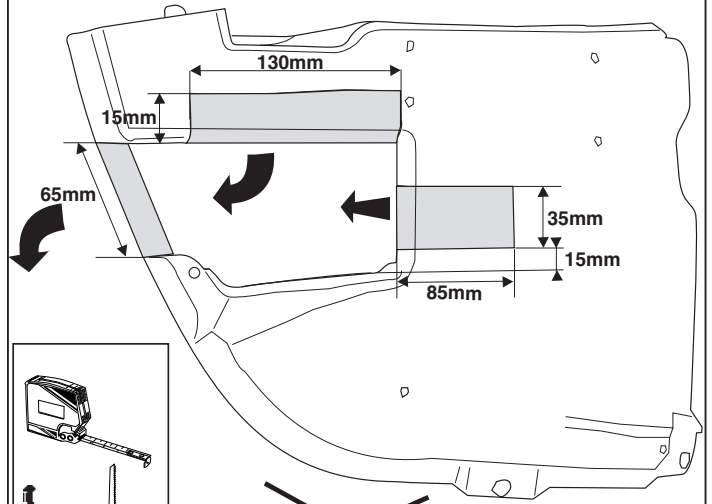

10

© 365370/16-06-2010/7

22 Option: Airsuspension only

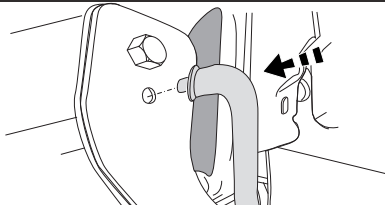

22

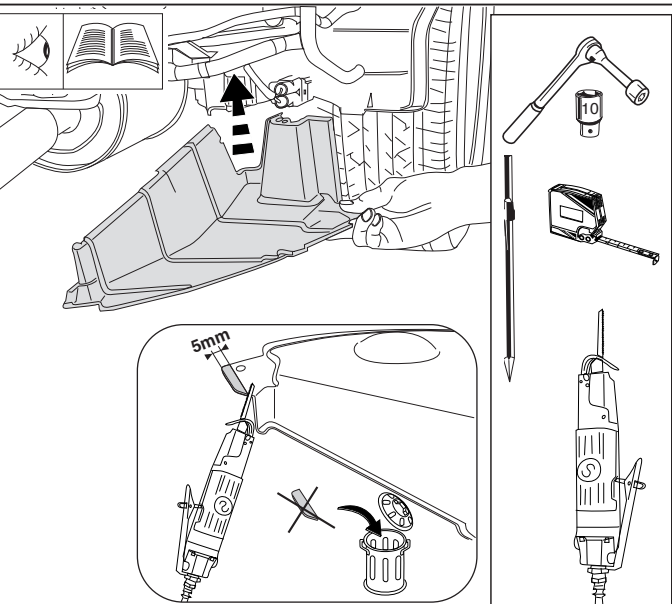

23 Option: Airsuspension only

23

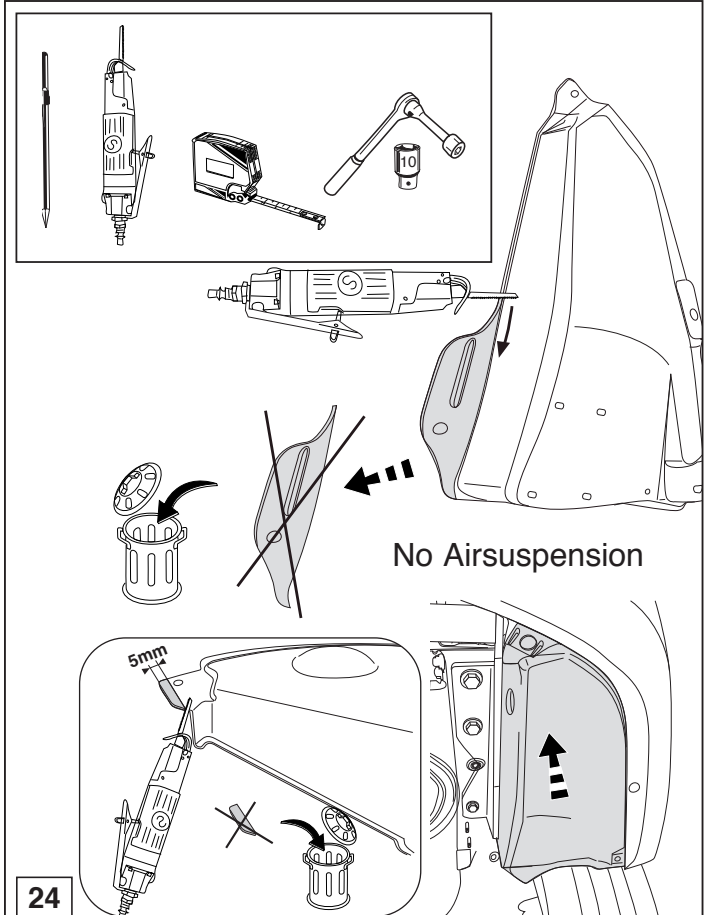

24

© 365370/16-06-2010/12



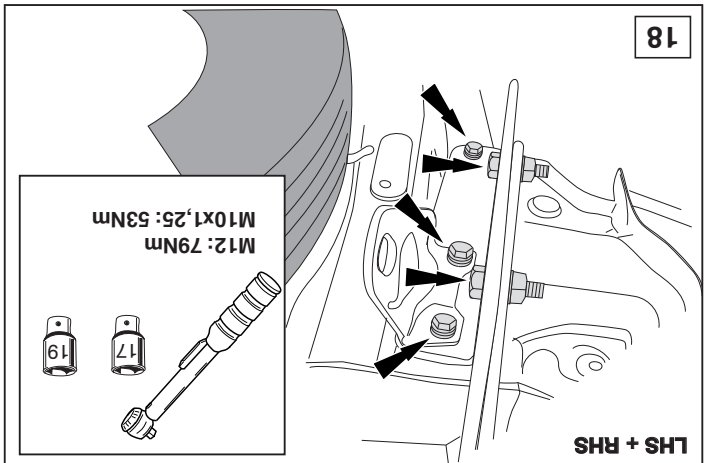
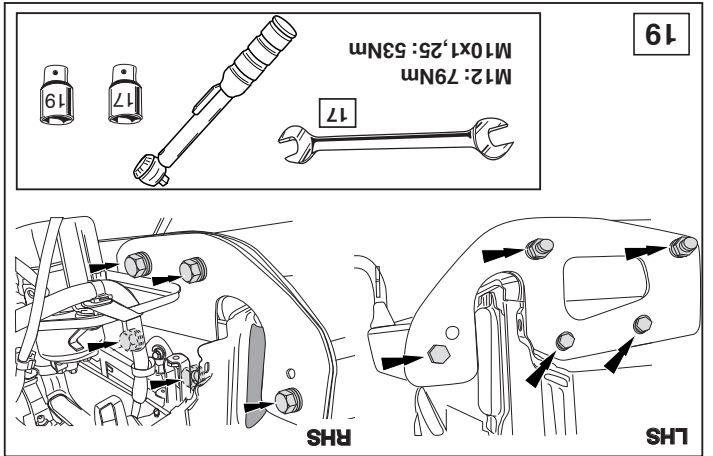
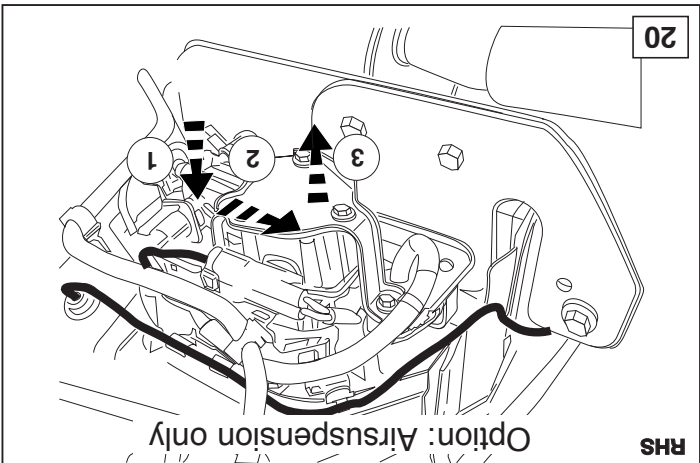
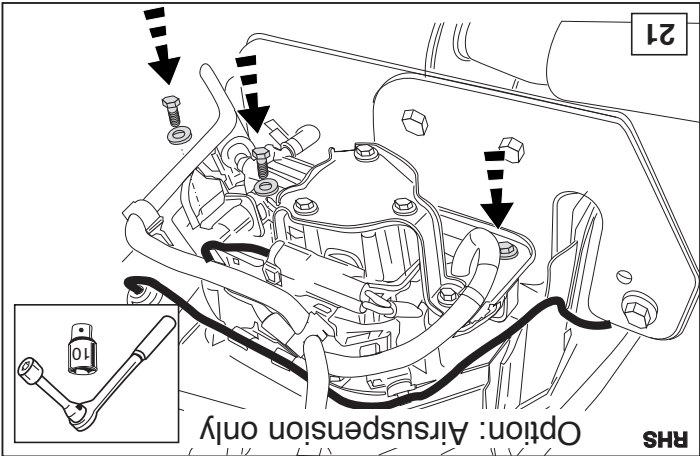
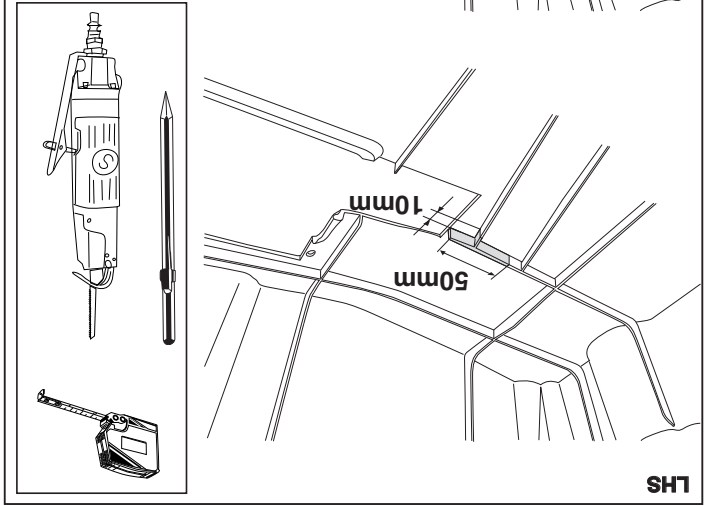
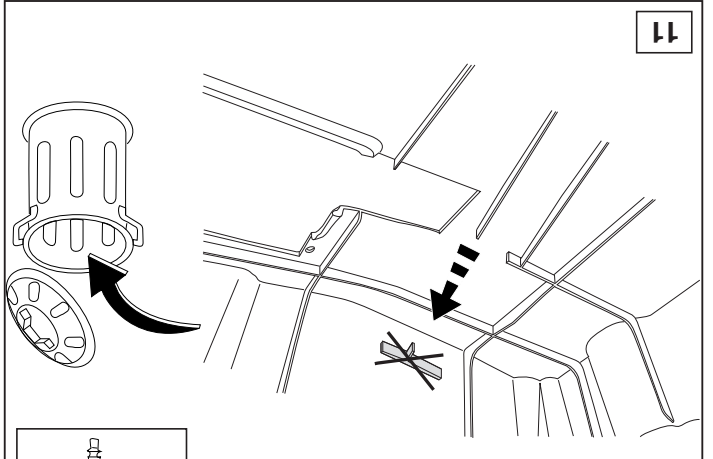
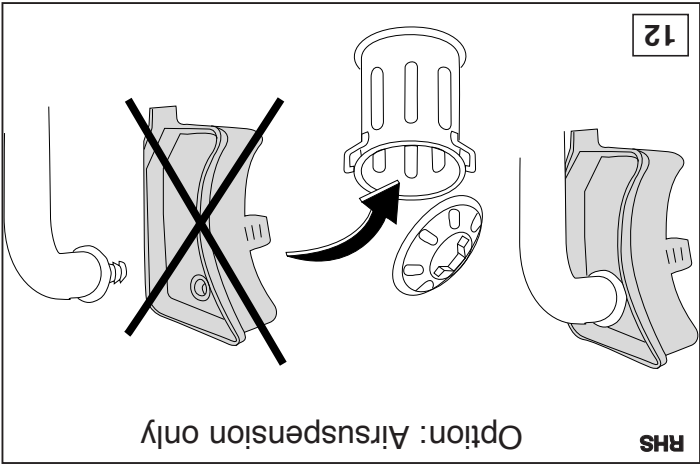
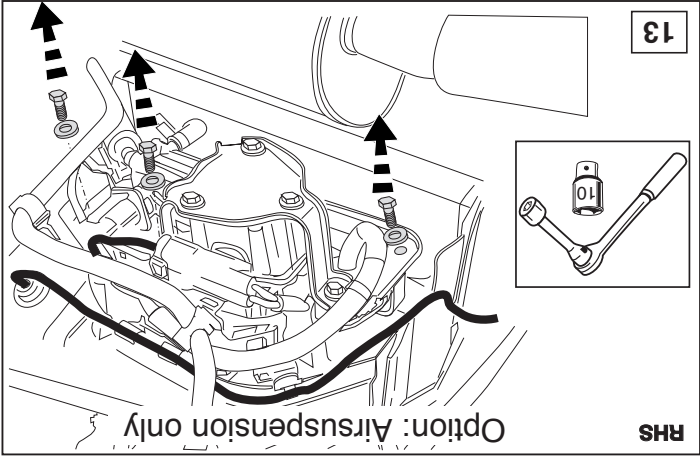

Option: Airsuspension only

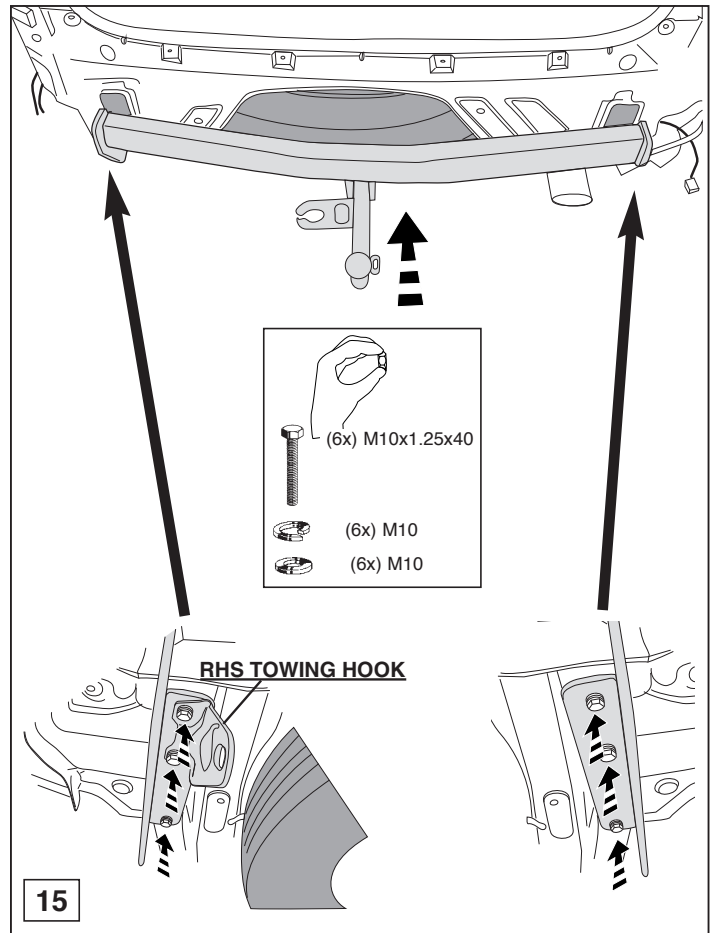
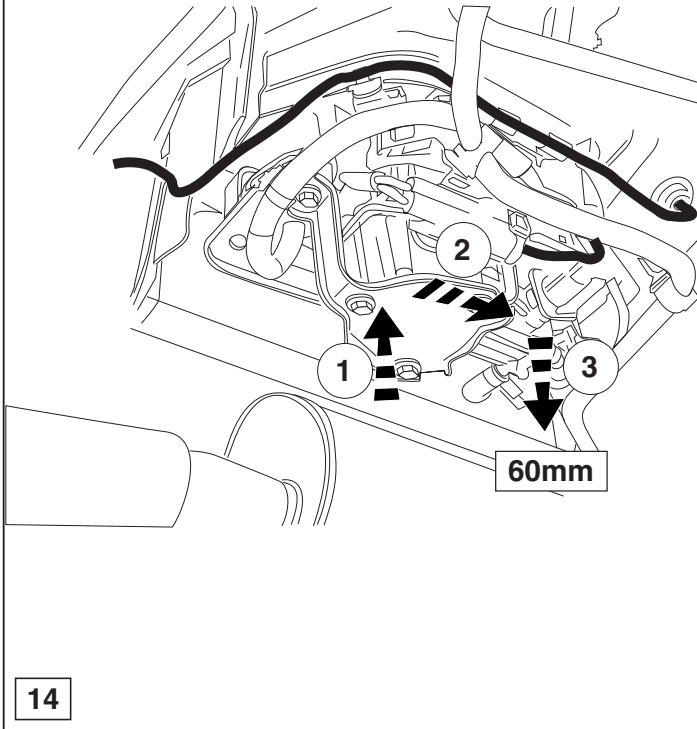

© 365370/16-06-2010/9

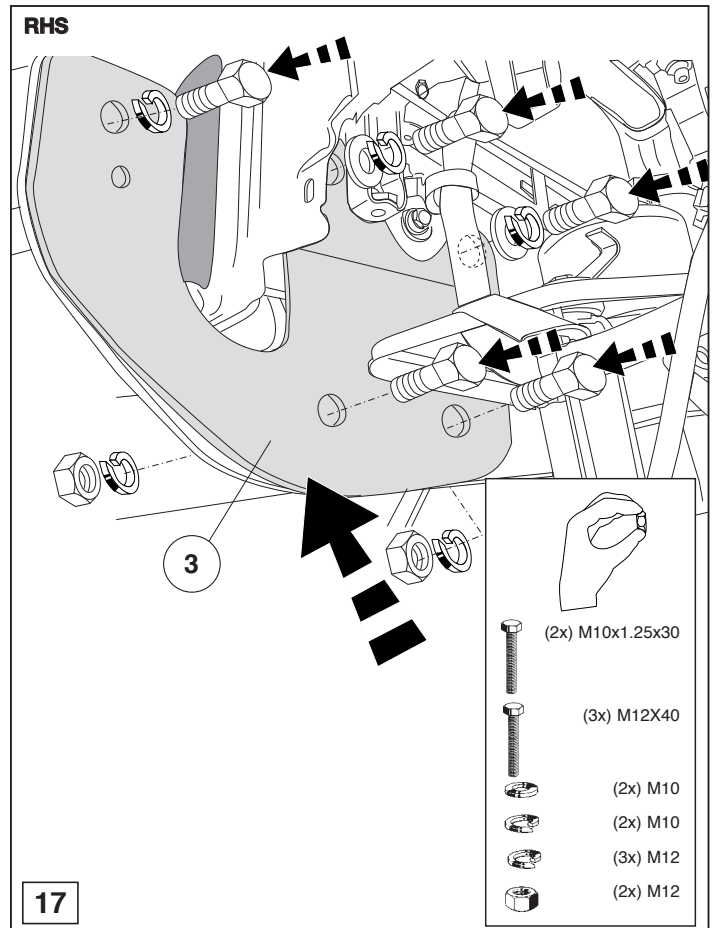
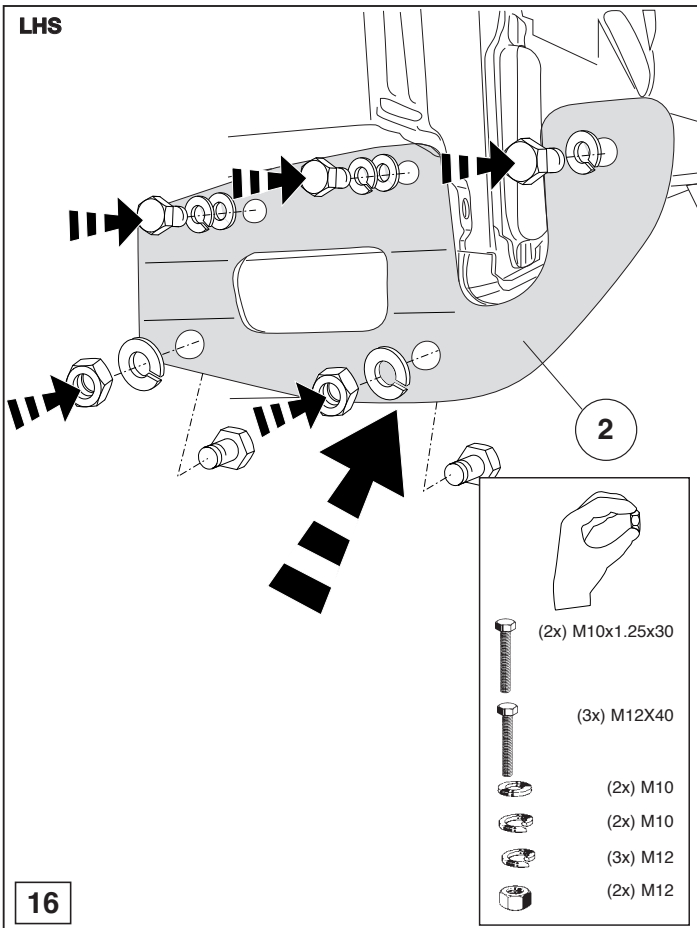

© 365370/16-06-2010/10