

bosal

**Инструкция
по монтажу тягово-сцепного
устройства шарового типа 6450 А
для автомобилей
SSANG YONG Actyon**

	2006 - ...
	1500
	75
	14,5



462800,

« - »

18

∴ (35363) 7-05-06
/ : (35363) 7-13-20
(495) 785-66-07

www.bosal-autoflex.ru

« - »	(8182) 22-48-15
" - "	8(8442) 98-74-98
" - "	8(343) 379-39-89, 373-42-73
" - "	8(343) 26-88-308
" - "	8(3952) 710-194
" - "	8(495) 777-54-59
" - "	8(495) 745-79-11
" - "	8(495) 788-95-97
" - "	8(495) 720-51-03
" - "	8(3532) 57-99-85
" - "	8-905-899-5012
" - "	8(383) 291-59-60
" - "	8(831) 279-53-24
" - "	8(3422) 98-27-20
" - "	8(342) 220-87-87
" - "	8-927-002-90-06
" - "	8(3462) 24-00-44
" - "	8(3842) 21-14-76
" - "	8-902-940-4151
" - "	8(3452) 32-22-12, 41-52-62
" - "	8-961-213-0278
" - "	8-917-347-1700
" - "	8(351) 269-44-75, 900-72-73
" - "	8(3512) 773-76-91

41.55-2005.

4
2
6
I=83
« »

1		
2		
3		
4		
5		
6		
7		

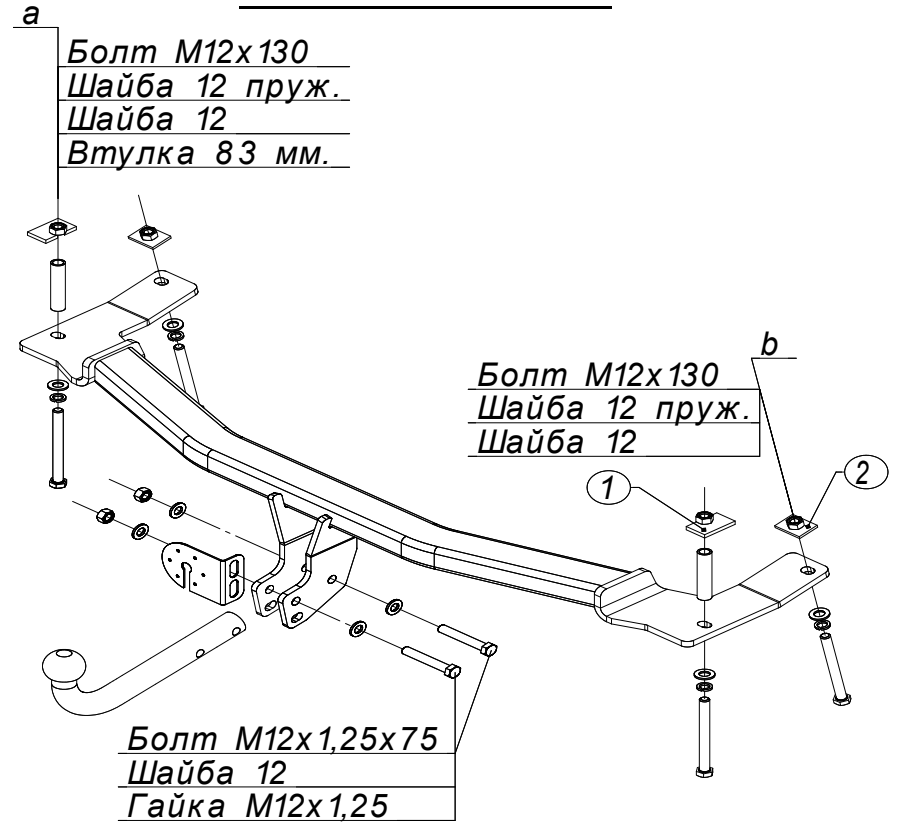
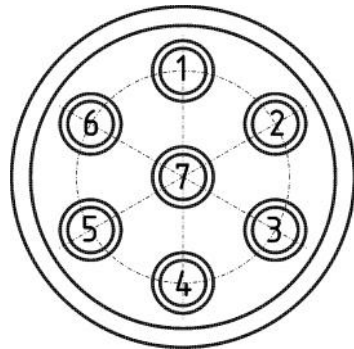

	1	.
	1	.
	1	.

		3	.
12 1,25 75		2	.
12 130		4	.
12 1,25		2	.
12		4	.
12		8	.
	1 (1)	2	.
	2 (2)	2	.
83		2	.
0837		1	.
		1	.
		1	.
		1	.
	190	1	.
		1	.

Схема обрезки кабеля

