

**TOW BAR V-125 FOR
VW Transporter T5
(Furgon, Minibus)
(2003 - r.)**

FITTING AND OPERATION MANUAL.

Cat. No. V-125

DESTINATION

Tow bar **V-125** for a **VW Transporter T5 (Furgon, Minibus)** is designed for towing a trailer. This ball hook has a current certification of approval authorizing the product with **e4** certification sign.

FITTING CONDITIONS

Tow bar **V-125** can be used and operated in a car with proper technical conditions of body elements. Those parts cannot be mechanically damaged. The ball hook has to be installed and operated in a car according to this instruction. All bolts and nuts in ball hook have to be screwed down with proper torque (Mo). Torque values are given below:

M8	-	25 (Nm)	M12	-	85 (Nm)
M10	-	50 (Nm)	M16	-	200 (Nm)

OPERATION CONDITIONS

The tow bar **V-125** has a rating plate describing correct and safe loads of the hook:

Typ: V-125	The tow bar for VW Transporter T5 (Furgon, Minibus)
A50-X	Tow bar class (compressing device)
e4 00- 3478	Tow bar certification of approval number
D = 14,2 kN	Teoretical related force working on a ball hook
S = 120 kg	Max permissible vertical load of the hook ball
R = 2800 kg	Max permissible load of towing trailer

D - force is calculated using the following formula:

$$D = g \times \frac{T \times R}{T + R} \text{ kN}$$

T-technically permissible maximum mass in tonnes of the towing vehicle (also towing tractors) including, if necessary, the vertical load of a centrale axle trailer.
R-technically permissible maximum mass in tonnes of the full trailer with drawgal free to move in the vertical plane or of the semi-trailer.
g-acceleration due to gravity (assumed as 9,81 m/s²)

During operating individual elements of ball hook should be kept in a proper technical condition and protected from corrosion. The trailer must be linked with an elastic joint with proper durability (cord , chain) while towing .It is necessary to check periodically bolt joints during operating the ball hook. If screws are eased , it is necessary to screw them down .

FITTING

The tow bar **V-125** for **VW Transporter T5 (Furgon, Minibus)** is made up of elements as follows :

- | | | | |
|--------------------------------|------------|-----------------------|------------|
| 1. Tow bar mainframe | - 1 piece | 6. Bolt M12x70 | - 2 pieces |
| 2. Tow ball | - 1 piece | 7. Flat washer 13,0 | - 2 pieces |
| 3. Electrical socket plate | - 1 piece | 8. Spring washer 12,2 | - 8 pieces |
| 4. Special washer 40/ 12,5x2,5 | - 6 pieces | 9. Nut M12 | - 4 pieces |
| 5. Bolt M12x30 | - 6 pieces | | |

Follow the general directions in order to fit **V-125** tow bar properly:

- 1.Rear bumper cutting **is not required**.
- 2.Dismantle the tow bar mainframe into hit form elements then dismantle rear bumper from the car.
- 3.Remove rear bumper's strengthening (it will not be installed at all).

- 4.Place (1) along internal sides of longitudinal chassis's frame elements then screw two the furthest located holes in each side with tow bar's mainframe using bolts (5) including (8) and (4).
- 5.Screw (1) through remaining holes using bolts (5) with (8), (4) and (9) (placed from internal side of longitudinal chassis's frame elements).
- 6.Assemble the rear bumper to the car.
- 7.Screw (2) and (3) to (1) using (6) with (7), (8) and (9).
- 8.Check if all fixing bolts and nuts are correctly tightened.

Obeying this instruction assures correct montage and the tow bar operating in a VW Transporter T5 (Furgon, Minibus).

After assembling of the tow bar **V-125** you have to get entry in cars **registration book** in a quality control station .

CAUTION :

All mechanical damages of tow bar excludes its further exploitation . Damaged ball hook **cannot be repaired**. In case of braking the rules of montage or unproper usage manufacturer **do not take responsibility** for arised damages .

MONTAGE DIAGRAM :

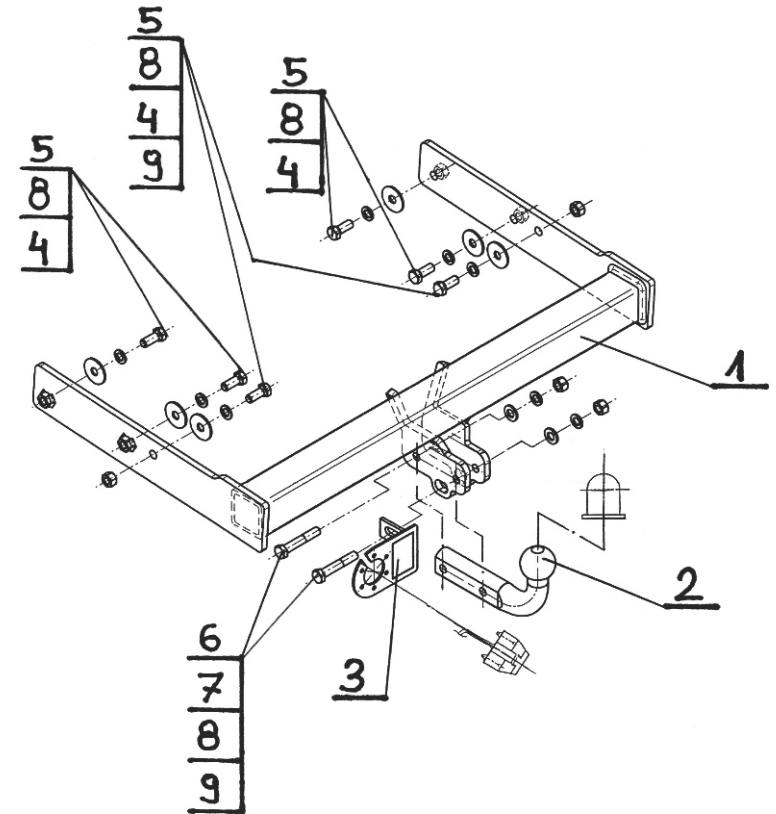

NOTE :

Bunch of wires is not included (in total price).